

CX210C Crawler Excavator

SERVICE MANUAL

Part number 47780398

English

October 2014

Copyright © 2014 CNH Industrial Italia S.p.A. All Rights Reserved.

CASE
CONSTRUCTION



SERVICE MANUAL

CX210C Crawler excavator LC version (TIER 4) - APAC Region - ANZ Market

Contents

INTRODUCTION

Engine.....	10
[10.001] Engine and crankcase	10.1
[10.102] Pan and covers	10.2
[10.101] Cylinder heads	10.3
[10.105] Connecting rods and pistons.....	10.4
[10.103] Crankshaft and flywheel.....	10.5
[10.216] Fuel tanks	10.6
[10.206] Fuel filters	10.7
[10.218] Fuel injection system.....	10.8
[10.250] Turbocharger and lines.....	10.9
[10.254] Intake and exhaust manifolds and muffler	10.10
[10.501] Exhaust Gas Recirculation (EGR) - Diesel Particulate Filter (DPF) exhaust treatment	10.11
[10.400] Engine cooling system	10.12
[10.414] Fan and drive	10.13
[10.310] Aftercooler.....	10.14
[10.304] Engine lubrication system.....	10.15
[10.408] Oil cooler and lines.....	10.16
Hydraulic systems.....	35
[35.000] Hydraulic systems.....	35.1
[35.300] Reservoir, cooler, and filters.....	35.2
[35.106] Variable displacement pump	35.3
[35.102] Pump control valves.....	35.4
[35.304] Combination pump units	35.5
[35.359] Main control valve.....	35.6
[35.357] Pilot system	35.7

[35.525] Auxiliary hydraulic valves and lines	35.8
[35.355] Hydraulic hand control	35.9
[35.356] Hydraulic foot control.....	35.10
[35.352] Hydraulic swing system	35.11
[35.353] Hydraulic travel system	35.12
[35.354] Hydraulic central joint	35.13
[35.736] Boom hydraulic system	35.14
[35.737] Dipper hydraulic system.....	35.15
[35.738] Excavator and backhoe bucket hydraulic system.....	35.16
[35.734] Tool quick coupler hydraulic system	35.17
Frames and ballasting	39
[39.140] Ballasts and supports	39.1
Tracks and track suspension.....	48
[48.130] Track frame and driving wheels.....	48.1
[48.100] Tracks	48.2
[48.134] Track tension units	48.3
[48.138] Track rollers	48.4
Cab climate control	50
[50.100] Heating.....	50.1
[50.200] Air conditioning.....	50.2
Electrical systems	55
[55.000] Electrical system	55.1
[55.100] Harnesses and connectors.....	55.2
[55.015] Engine control system.....	55.3
[55.201] Engine starting system	55.4
[55.301] Alternator.....	55.5
[55.302] Battery.....	55.6
[55.202] Cold start aid	55.7

**Thanks very much for your reading,
Want to get more information,
Please click here, Then get the complete
manual**

JustClickHere 

NOTE:

**If there is no response to click on the link above,
please download the PDF document first, and then
click on it.**

**Have any questions please write to me:
admin@servicemanualperfect.com**

[55.010] Fuel injection system	55.8
[55.014] Engine intake and exhaust system.....	55.9
[55.989] Exhaust Gas Recirculation (EGR) electrical system	55.10
[55.012] Engine cooling system	55.11
[55.013] Engine oil system	55.12
[55.640] Electronic modules	55.13
[55.512] Cab controls.....	55.14
[55.036] Hydraulic system control	55.15
[55.051] Cab Heating, Ventilation, and Air-Conditioning (HVAC) controls.....	55.16
[55.050] Heating, Ventilation, and Air-Conditioning (HVAC) control system.....	55.17
[55.524] Cab controls (Lift arm, Boom, Dipper, Bucket).....	55.18
[55.416] Swing control system	55.19
[55.417] Travel control system	55.20
[55.950] Hammer electric system	55.21
[55.530] Camera.....	55.22
[55.518] Wiper and washer system.....	55.23
[55.404] External lighting	55.24
[55.514] Cab lighting	55.25
[55.408] Warning indicators, alarms, and instruments	55.26
[55.992] Anti-theft system	55.27
[55.DTC] FAULT CODES.....	55.28
Booms, dippers, and buckets	84
[84.910] Boom.....	84.1
[84.912] Dipper arm	84.2
[84.100] Bucket.....	84.3
Platform, cab, bodywork, and decals.....	90
[90.150] Cab.....	90.1
[90.156] Cab glazing	90.2
[90.120] Mechanically-adjusted operator seat.....	90.3

[90.100] Engine hood and panels 90.4



INTRODUCTION

Contents

INTRODUCTION

Foreword - Important notice regarding equipment servicing	3
Safety rules	4
Safety rules – General information	5
Safety rules	6
Safety rules – ROPS judgment method	8
Torque – Bolt and nut	16
Torque – Special torque settings	17
Basic instructions - Shop and assembly	21
General specification	23
General specification – Main equipment	26
Weight	32
Dimension	35
Conversion factors	37
Consumables	49
Capacities	52
Abbreviation	53
Product identification	56
Product identification - Machine orientation	59

Foreword - Important notice regarding equipment servicing

All repair and maintenance work listed in this manual must be carried out only by qualified dealership personnel, strictly complying with the instructions given, and using, whenever possible, the special tools.

Anyone who performs repair and maintenance operations without complying with the procedures provided herein shall be responsible for any subsequent damages.

The manufacturer and all the organizations of its distribution chain, including - without limitation - national, regional, or local dealers, reject any responsibility for damages caused by parts and/or components not approved by the manufacturer, including those used for the servicing or repair of the product manufactured or marketed by the manufacturer. In any case, no warranty is given or attributed on the product manufactured or marketed by the manufacturer in case of damages caused by parts and/or components not approved by the manufacturer.

The manufacturer reserves the right to make improvements in design and changes in specifications at any time without notice and without incurring any obligation to install them on units previously sold. Specifications, descriptions, and illustrative material herein are as accurate as known at time of publication but are subject to change without notice.

In case of questions, refer to your CASE CONSTRUCTION Sales and Service Networks.

Safety rules

Personal safety





This is the safety alert symbol. It is used to alert you to potential personal injury hazards. Obey all safety messages that follow this symbol to avoid possible death or injury.

Throughout this manual you will find the signal words **DANGER**, **WARNING**, and **CAUTION** followed by special instructions. These precautions are intended for the personal safety of you and those working with you.

Read and understand all the safety messages in this manual before you operate or service the machine.

 **DANGER** indicates a hazardous situation that, if not avoided, will result in death or serious injury.

 **WARNING** indicates a hazardous situation that, if not avoided, could result in death or serious injury.

 **CAUTION** indicates a hazardous situation that, if not avoided, could result in minor or moderate injury.

FAILURE TO FOLLOW DANGER, WARNING, AND CAUTION MESSAGES COULD RESULT IN DEATH OR SERIOUS INJURY.

Machine safety

NOTICE: *Notice indicates a situation that, if not avoided, could result in machine or property damage.*

Throughout this manual you will find the signal word **Notice** followed by special instructions to prevent machine or property damage. The word **Notice** is used to address practices not related to personal safety.

Information

NOTE: *Note indicates additional information that clarifies steps, procedures, or other information in this manual.*

Throughout this manual you will find the word **Note** followed by additional information about a step, procedure, or other information in the manual. The word **Note** is not intended to address personal safety or property damage.

Safety rules – General information

Cleaning

Clean the metal parts with cleaning solution that meets the standard and steam cleaning. (except for bearings)

After cleaning, dry well, and inject oil in all parts.

Also inject oil into the bearings after drying.

Inspection

When disassembling parts, check all the parts.

If there are any worn or damaged parts, replace them.

Inspect carefully to prevent initial breakdowns.

Bearing

Replace any loose bearings.

Air dry bearings before installing them.

Needle bearing

When inserting needle bearings, be very careful not to damage them.

Apply grease to the section where the needle bearing will be inserted.

Gear

Check that there is no wear and no damage.

Oil seal, O-ring, gasket

Always install new oil seals, O-rings, and gaskets.

Apply grease to sections where oil seals and O-rings will be inserted.

Shaft

Check that there is no wear and no damage.

Check the bearings and check for damaged oil seals on the shaft.

Service parts

Install CASE CONSTRUCTION genuine service parts.

When placing an order, check the parts catalog. It contains the CASE CONSTRUCTION genuine part numbers.

Any breakdowns arising from the installation of non-genuine parts are not covered by the warranty.

Lubricants (fuel, hydraulic oil)

Use the oil from the specified company or specified in the operator's manual or service Manual.

Any breakdowns arising from any fuel or hydraulic oil other than those specified are not covered by the warranty.

Safety rules

WARNING:

This symbol indicates the need for caution.

Details are given concerning the safety of the operator and the surroundings.

Read all cautions carefully and understand them well before starting any work.

In order to prevent any accidents, always comply with warnings and cautions.

This section covers overall dangers.

Check if warning labels are installed.

Additional warning labels are available for order as a service part.

WARNING:

Read this operator's manual well to have a thorough understanding of how to control and operate this machine.

WARNING:

Always operate this machine from the seated position.

Any other method of operation has the danger of severe injury.

WARNING:

This machine is for only 1 person to ride on. Do not ride 2 people on this machine.

WARNING:

Before starting the engine, check the safety messages in this operator's manual.

Check all the warning labels on the machine.

Check that there is no one anywhere in or around the work range for the machine.

Check the operation methods in a safe location before starting the actual work.

Understand the operation of this machine well, then operate it according to service-related laws and ordinances.

The operator's manual and service manual can be ordered from any CASE CONSTRUCTION dealer.

WARNING:

Working in untidy work clothes or in clothes with which safety cannot be ensured leads to damage to the machine and injury of the operator themselves.

Always work dressed for safety.

In order to work more safely, it is recommended to wear additional safety gear.

(Helmet, safety shoes, earplugs, goggles, work clothes, and gloves)

WARNING:

Work with great care when the engine is running.

WARNING:

Check and verify hydraulic equipment.

Work according to the procedure.

Do not change the procedure.

WARNING:

When bleeding the pressure from hydraulic circuits to inspect the machine's hydraulic cylinders, make sure that there is no one in the vicinity before doing the work.

 **WARNING:**

Use gloves when handling hot parts.

 **WARNING:**

Lower the parts to the ground before inspecting or repairing attachments and lower parts.

 **WARNING:**

Check that all hoses and tubes are securely connected.
Replace any damaged hose or tube.
Do not use your hands to check for oil leaks. Use a piece of cardboard or wood.

 **WARNING:**

When removing an attachment pin or other hard pin, use a hammer with a soft head.

 **WARNING:**

When installing a pin with a hammer and working with a grinder, wear protective eyewear.
At this time, use goggles or a protector that meets the standards.

 **WARNING:**

When repairing or inspecting, stop the machine at a safe location.

 **WARNING:**

When repairing the machine, protect the work site.
Check the oil, coolant, grease, and tools.
Collect materials and parts as necessary.
Pay careful attention to work safely.

 **WARNING:**

Some of the machine's parts are extremely heavy.
In this case, use an appropriate crane.
For details on the weights and correct procedures, see the Service Manual.

 **WARNING:**

Exhaust gas is harmful.
When working indoors or in any other enclosed space, always use good ventilation.

 **WARNING:**

If battery solution is frozen, there is a danger of it exploding.

Safety rules – ROPS judgment method

1. Purpose

Check against the ROPS judgment criteria to judge whether the machine satisfies the ROPS criteria or not.

The weight and boom of the machine greatly effects whether the ROPS judgment criteria is satisfied or not.

The ROPS test assumes that the weight being used is the weight of the machine when the maximum number of selectable options are mounted (as of 2009).

However, depending on the derivative machinery or the order details, the weight and boom position may differ from the assumed weight or position.

2. Criteria for judging whether a machine satisfies the ROPS criteria

Weight

The weight must not be over the weight shown below for each class.

If the weight is exceeded, there is a danger that the cab could be damaged and the operator could die or sustain a serious injury when the machine falls over.

If the weight exceeds the stipulated weight, the machine will not satisfy the ROPS criteria.

- Weight (X3 model)

To satisfy the ROPS criteria, the weight must not be over the indicated weight. (The below weights are the weights indicated on the plate within the ROPS cab.)

Machine body total weight	Class
16000 kg (35273.962 lb) max.	CX75C CX80C CX145C
20500 kg (45194.764 lb) max.	CX130C CX160C
28000 kg (61729.433 lb) max.	CX235C
31000 kg (68343.301 lb) max.	CX210C CX250C CX250C LR CX300C
50000 kg (110231.131 lb) max.	CX470C

* The ROPS test assumes that the CX470C has a cage guard (alone).

- Weight (X2 model)

To satisfy the ROPS criteria, the weight must not be over the indicated weight. (The below weights are the weights indicated on the plate within the ROPS cab.)

Machine body total weight	Class
26600 kg (58642.962 lb) max.	CX130B CX160B CX180B CX210B CX240B

Boom position

WARNING:

- If the machine has been modified so that the boom position has been lowered, the machine will not satisfy the ROPS criteria.
- It is necessary to consult with us if it is possible that the boom's position has been lowered by modification.
- The extent to which a boom position has moved cannot be determined in the same way for all machines.

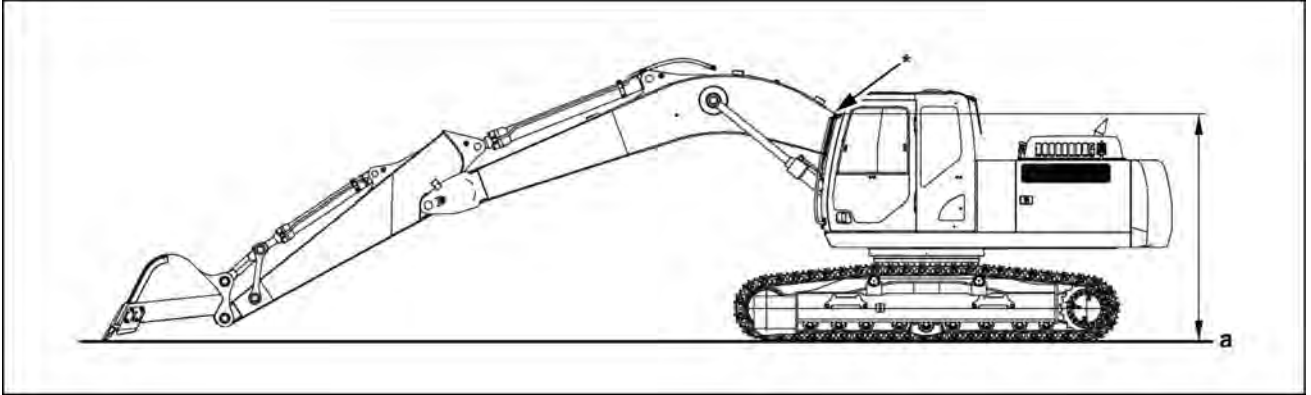

LPIL12CX00001EB 1

a. Ground point

With the tip of the bucket in contact with the ground surface at maximum work radius, if the position (* in the diagram) that overlaps with the cab when viewed from the side is markedly lower than that of a standard machine (standard arm), the machine will not satisfy the ROPS criteria.

Also, with a machine body with a cab mounted that can withstand up to **31 t (68343.30 lb)**, the effect of mounting a **24 t (52910.94 lb)** machine, which is near the restriction weight, and a **21 t (46297.08 lb)** machine to the same cab will not be the same.

3. Prohibited items

- Modifications that reduce the strength of a platform that has a cab with a ROPS mounted to it. (Actions or modifications that reduce the functionality of the anchoring part at the left-rear of the cab)
- Modifications that effect the strength of the ROPS of a cab.

Modification prohibited (red part)	All modifications (grinding, welding, drilling holes, removing, etc.) are prohibited
Modification permitted under conditions (gray part)	Removal of parts is prohibited Bar welding and making holes [up to diameter 20 mm (0.787 in)] by drilling are possible

INTRODUCTION

[X3 cab (CX75C/CX80C/CX145C)]

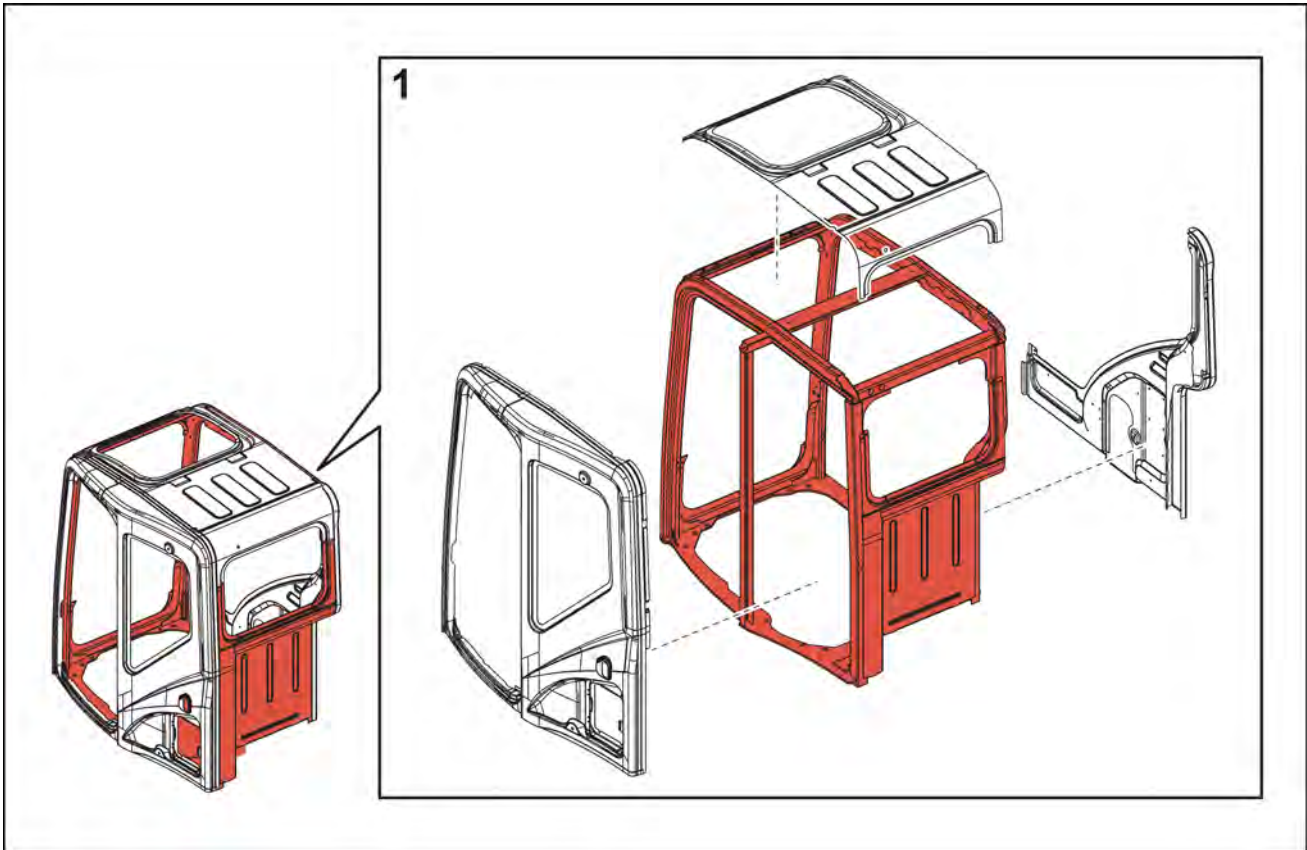

SMIL14CEX2341FA 2

INTRODUCTION

[X3 cab (CX235C)]

The cab for the MSR model (CX235C) is the cab of the MSR model on the diagram (CX75C/CX80C/CX145C) with reinforcement materials added in 3 locations.

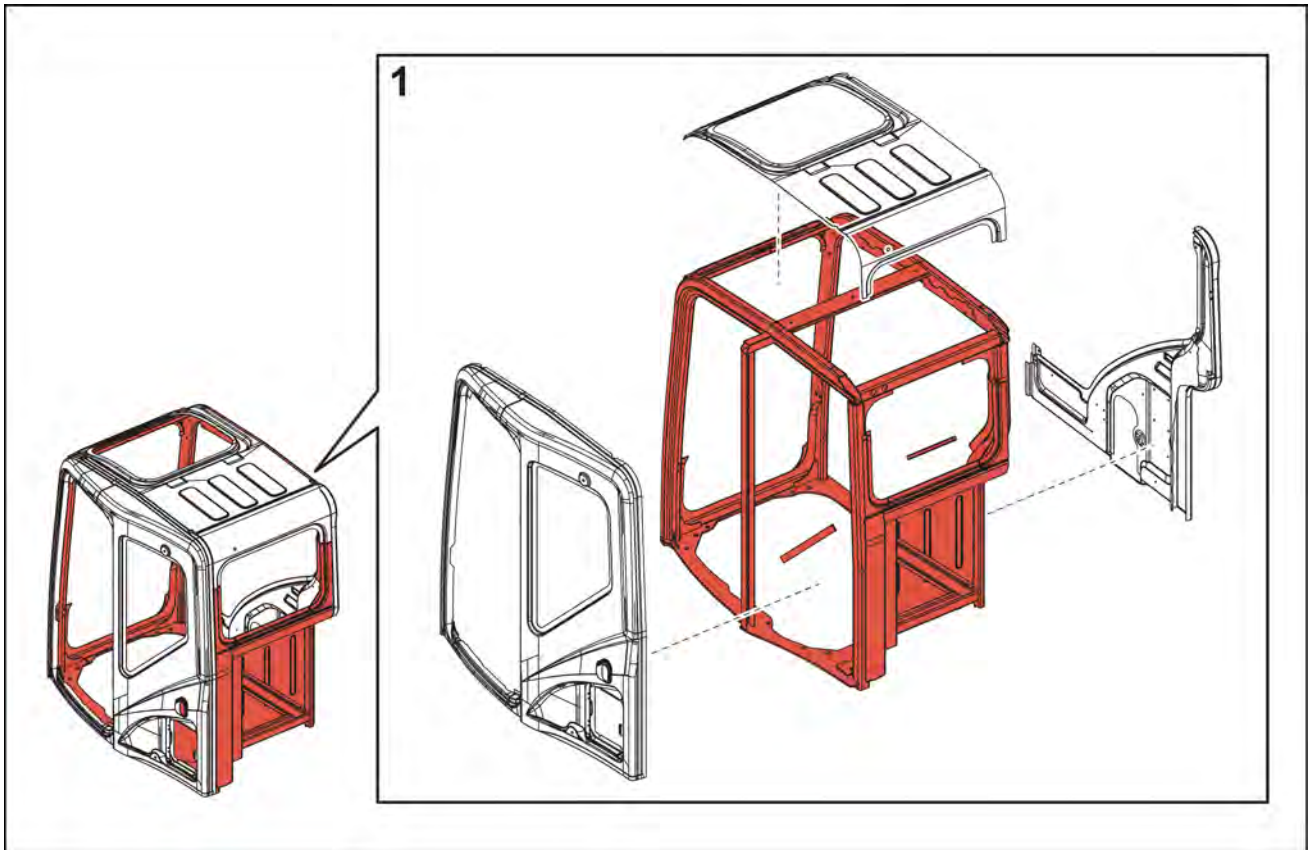

SMIL14CEX2342FA 3

[X3 cab (CX130C/CX160C)]

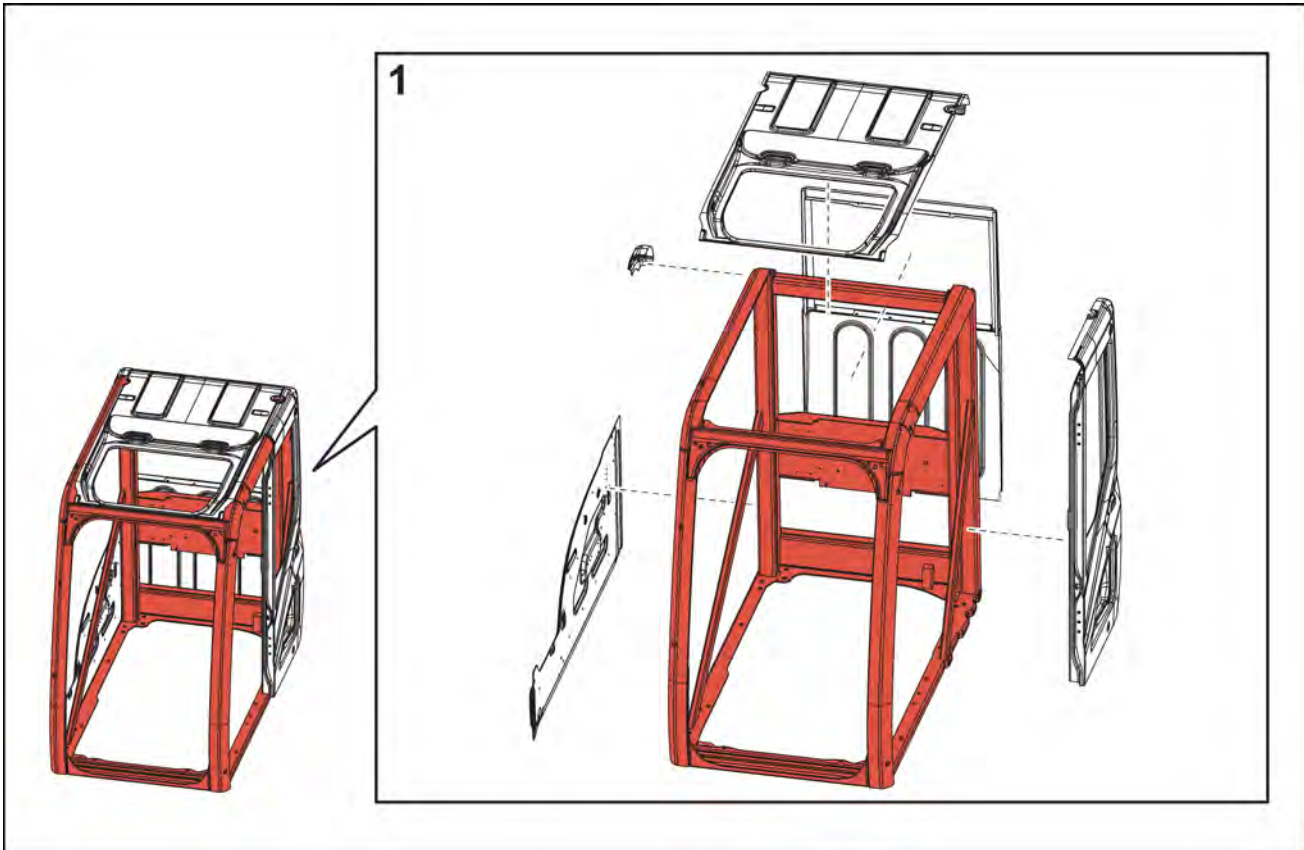

SMIL14CEX2343FA 4

[X3 cab (CX210C/CX240C/CX290C)]

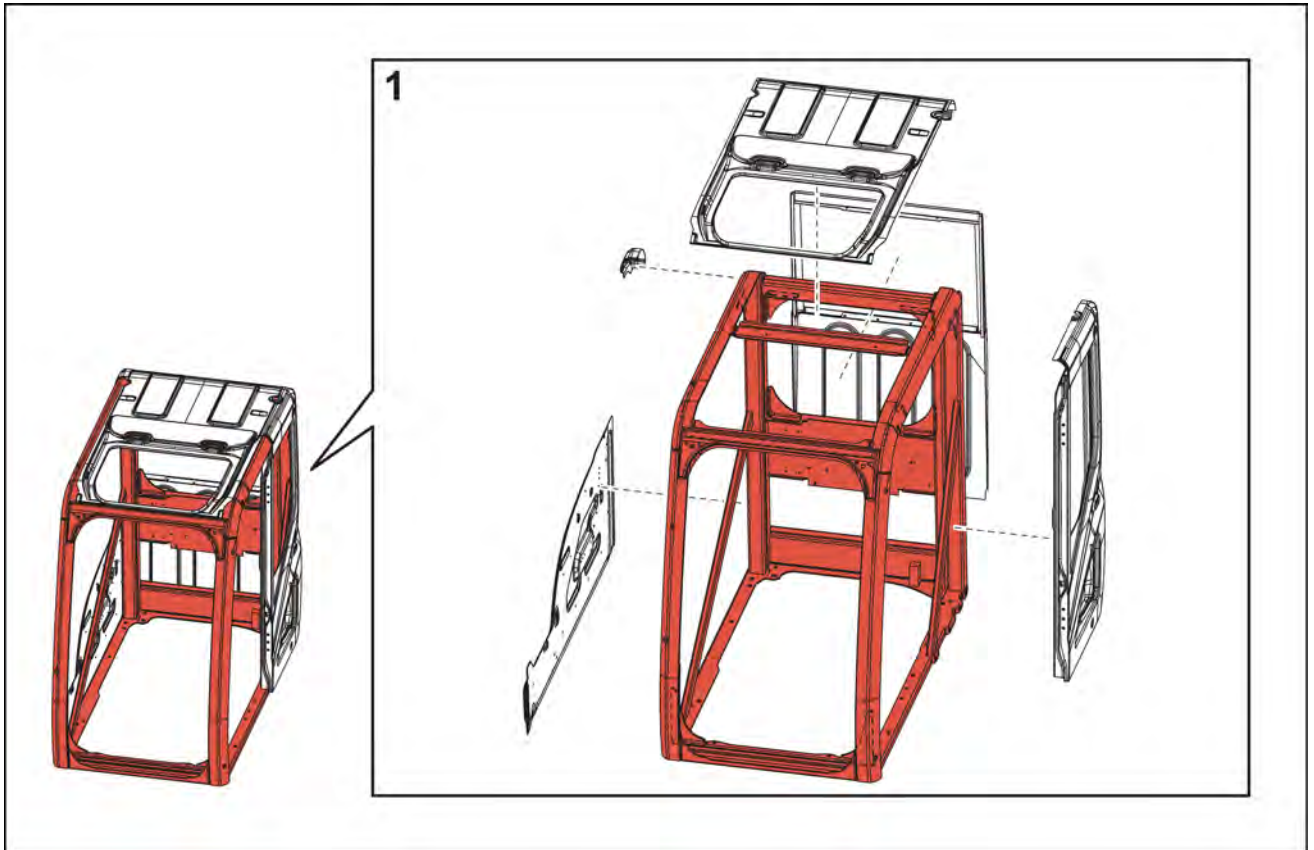

SMIL14CEX2344FA 5

INTRODUCTION

[X3 cab (CX350C)]

The cab for the large-sized model (CX350C) is the cab of the medium-sized model on the diagram (CX210C - CX290C) with reinforcement materials added in 7 locations.

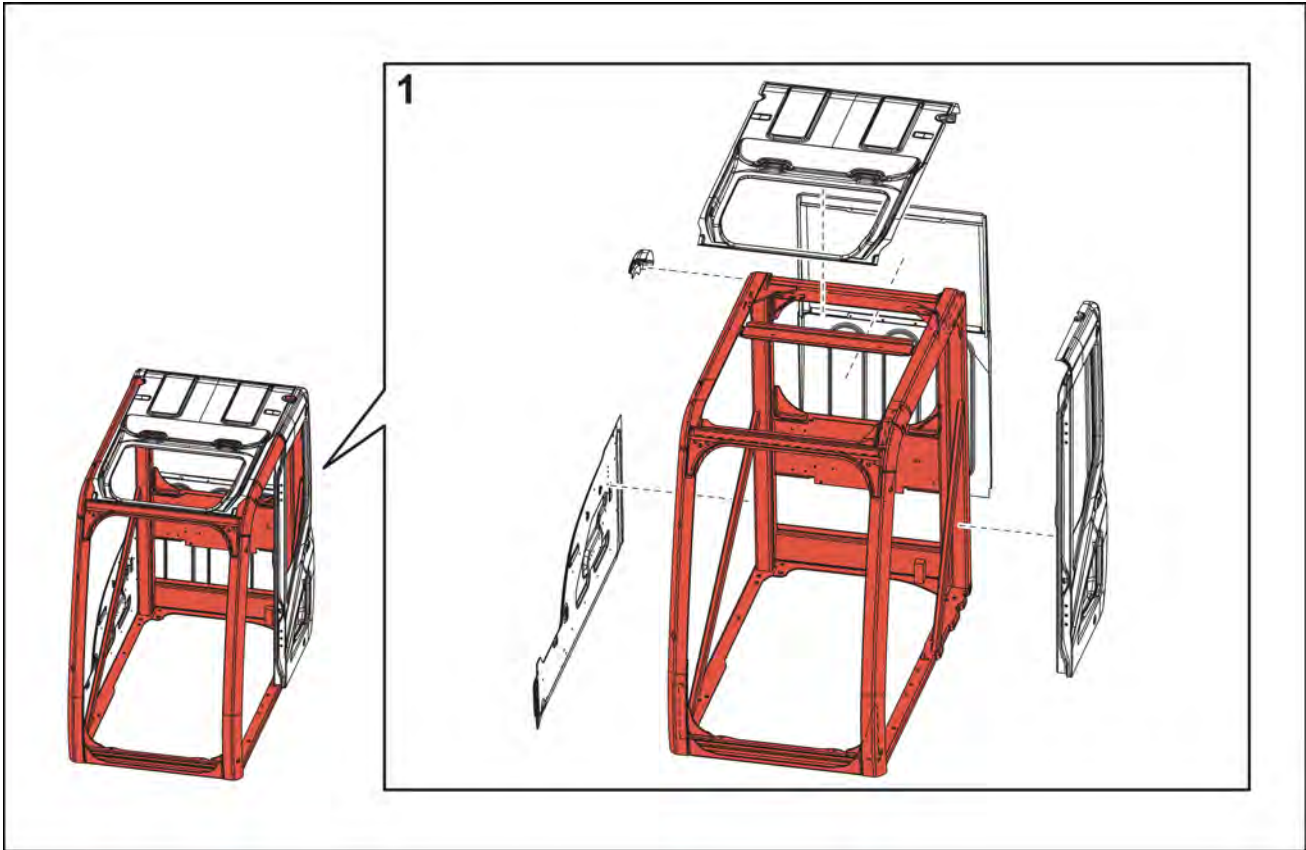

SMIL14CEX2345FA 6